

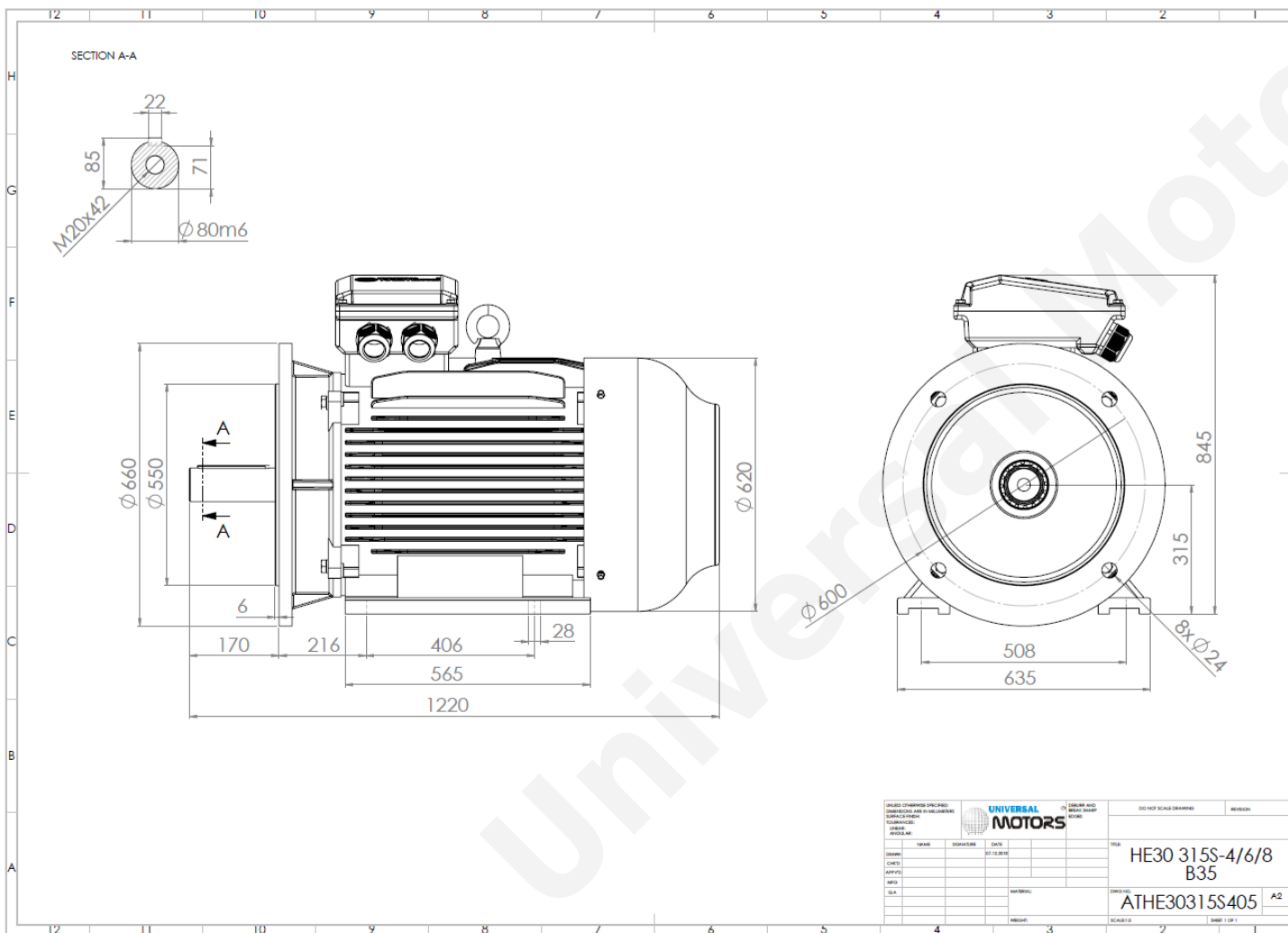

TECHNICAL DATA

Three Phase Electric Motors - Cast Iron Frame
 HE30 315S-4 IE2
 110 kW / 150 Cv
 1480 RPM



Motor type:	HE30 315S-4 IE2
Output:	110 kW / 150 Cv
Speed (min ⁻¹):	1480 RPM
Frequency:	50 Hz
Voltage:	400 V
Current:	191 A
Power factor (Cos Ø):	0.88
Poles:	4
Insulation class:	F
Temperature rise Class:	B
Efficiency 50%:	93.8 %
Efficiency 75%:	95.0 %
Efficiency 100%:	94.5 %
Torque:	710 N.m
Tstarting/Tnominal:	2.0
Istarting/Inominal:	7.1
Tmaximum/Tnominal:	2.2
Noise:	77 Db(A)
Weight:	898 Kg
Bearing DE:	NU 319
Bearing NDE:	6319 C3

Regime - S1

Altitude - 1000m

Environment Temperature - 40°C

CONTACTS:

UNIVERSAL MOTORS Tel: +351 252 299 080
 Rua de São Brás,745 Fax: +351 252 299 089
 4480-782 VILA DO CONDE Mail: geral@universalmotors.pt

* References applied only in the UK